

DL1 Pool Ladder

Owner's Manual

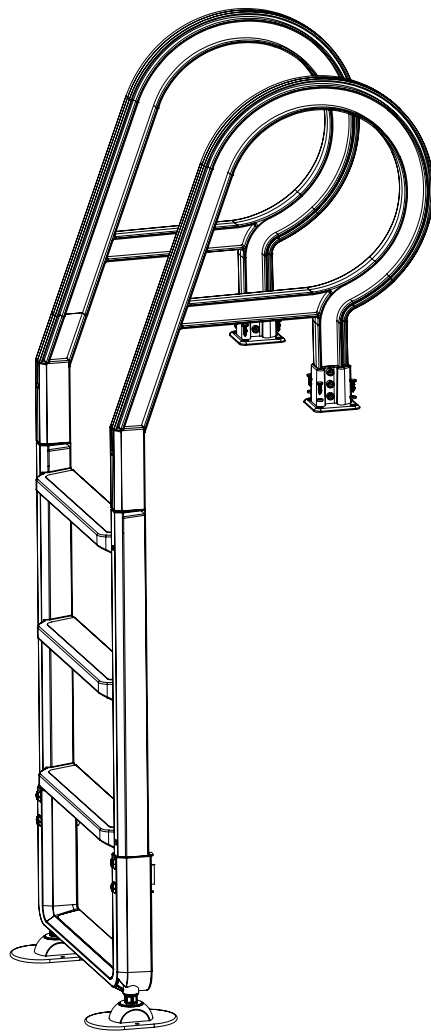

DL1-W



Scan to register your
product warranty

GoPool

Warranty registration

Thank you for choosing GoPool! Register your product today to activate your warranty and get quick, hassle-free support when you need it.



Scan to register your product warranty







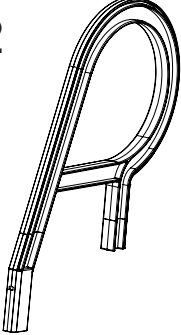
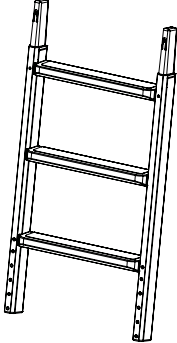
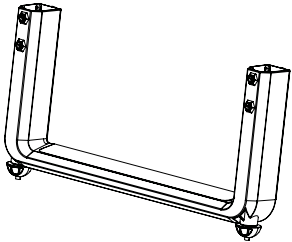

WARNING

This equipment must be installed and serviced according to the information found in this manual. Improper installation can create hazards which could result in property damage, serious injury or death. Improper installation will void the warranty.

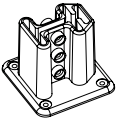
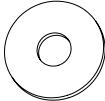
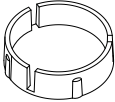
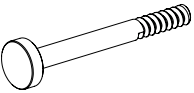
Table of contents

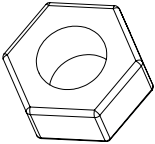
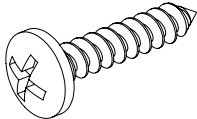
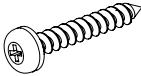
Installation manual	1
Safety instructions.....	2
Steps	3
Pieces.....	6

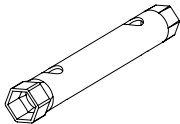
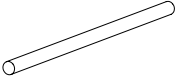
1 ×2 	2 ×1 	3 ×1 			
4 ×2 	5 ×2 	6 ×2 	7 ×2 	8 ×4 	9 ×4 
10 ×4 	11 ×10 	12 ×4 	13 ×4 	14 ×1 	15 ×1 

Important safety instructions



CAUTION: To prevent damage to the ladder and minimize the risk of injury, please follow these instructions carefully.

- Install the ladder on a solid base.
- For **ENTRY/EXIT** of the pool, always face the pool. This ladder is **ONLY** for entering and exiting the pool. Any other use may damage the ladder and the pool structure.
- **NO JUMPING.**
- **NO DIVING.**
- **MAXIMUM WEIGHT:** 102 KG / 225 LB
- To prevent entrapment or drowning, do not swim through, behind, or around the ladder.

WARNING: The space between the inside wall of the pool and the ladder should not exceed 4 inches to prevent a person from getting trapped while swimming. If the space between the wall and the ladder exceeds 4 inches, you must purchase a safety kit to avoid any accidents.

NOTE -

This ladder is designed and manufactured to fit above ground pools with a height of 48", 52" or 54".

- The ladder should be removed from the pool and stored in a dry place for the winter.

Steps



STEP 1:

Attach two of the feet(4) onto one of the "U" shaped ladder bases(3) using a stainless steel screw (11), a stainless steel washer(6) and a plastic cap (7) for each pad.

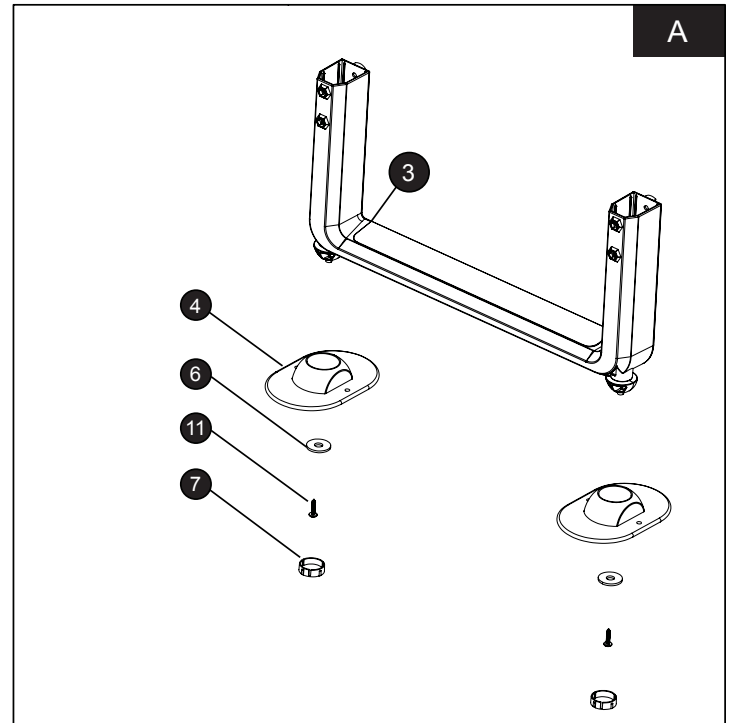

STEP 2:

Insert the ladder frame (2) into the assembled base (A). Adjust the height of part 2 plus base A according to the pool height (48", 52" or 54"). Secure the ladder base A) to the ladder frame (2) by inserting four bolts (8) into the four pre-drilled holes and fastening them with four washers (9) and four nuts (10) using the socket wrench tools (14) and (15).

NOTE -

During installation, suitable tools such as a mallet can be used to make the escalator fit more compactly.

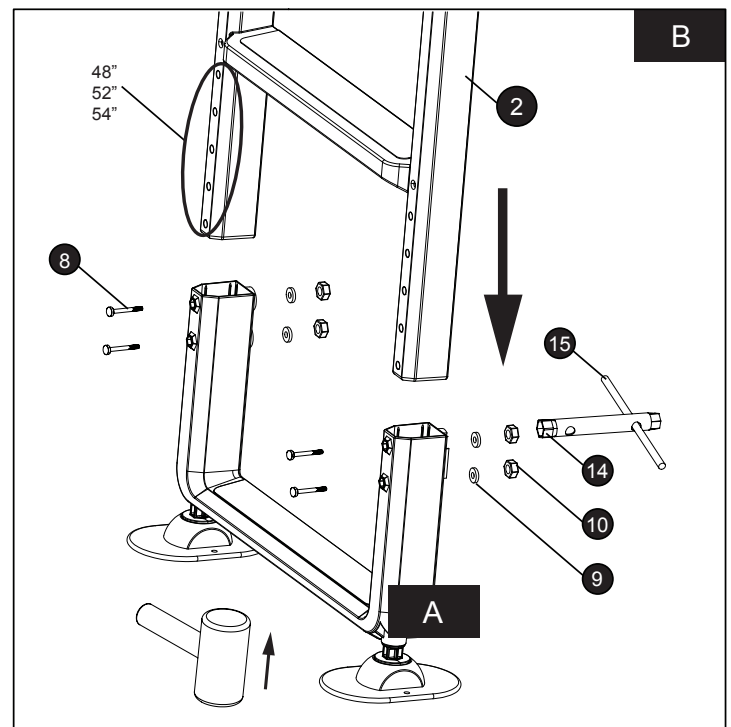

Next →

Steps



STEP 3:

NOTE -

The alignment is critical in this step. If necessary, it can be done with the relevant tools.

Insert the handrail (1) into the assembled ladder (B).

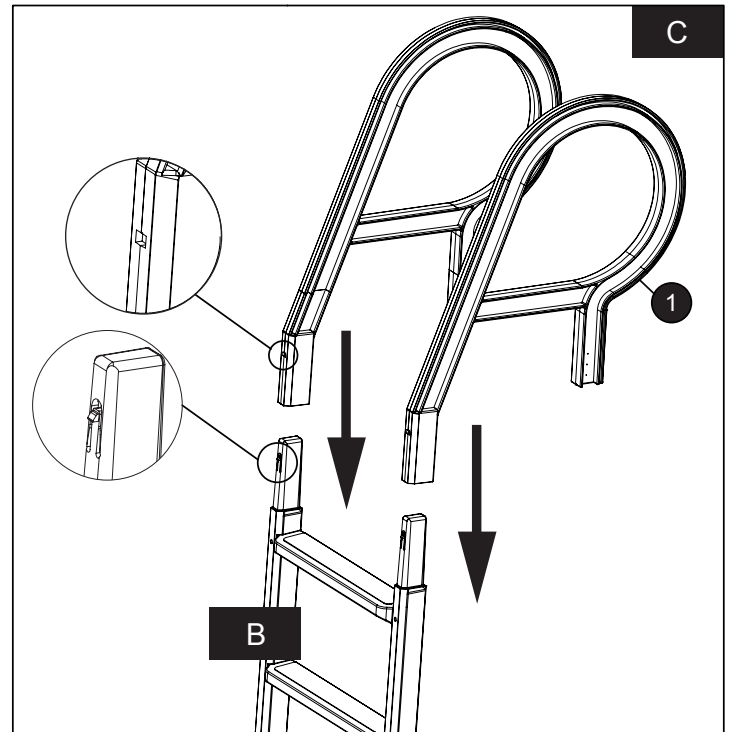

STEP 4:

Insert the bases (5) into the ends of the handrails, securing them with the corresponding screws (12) and washers (13). The height of the handrails can be adjusted by changing the position of the base (5).

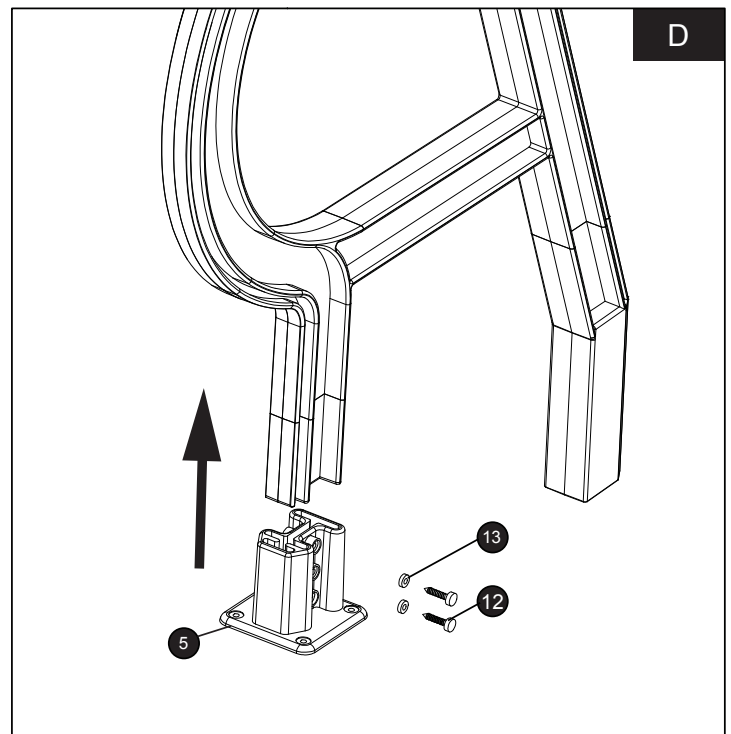

Next →

Steps



STEP 5:

Tightly attach the bases (5) to the platform using the washers and screws (11).

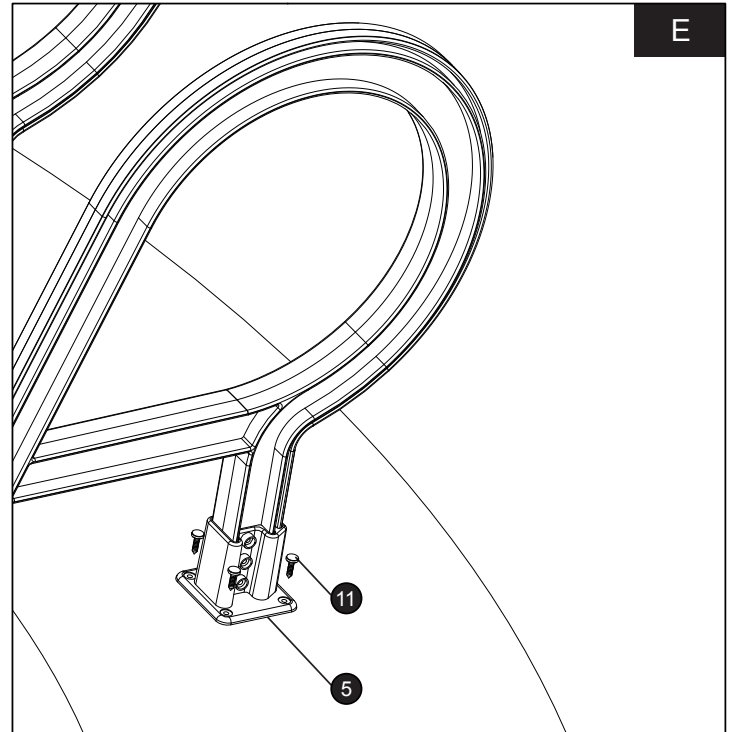

WARNING: The space between the pool's inner wall and the ladder should be no more than 4 inches to prevent entrapment between the ladder and the pool wall.

WARNING: This ladder can ONLY be used to enter and exit the pool. Any other use may damage the ladder and the pool structure.

WARNING: If there is a gap of more than 4 inches, the safety kit must be installed to prevent accidental drowning.

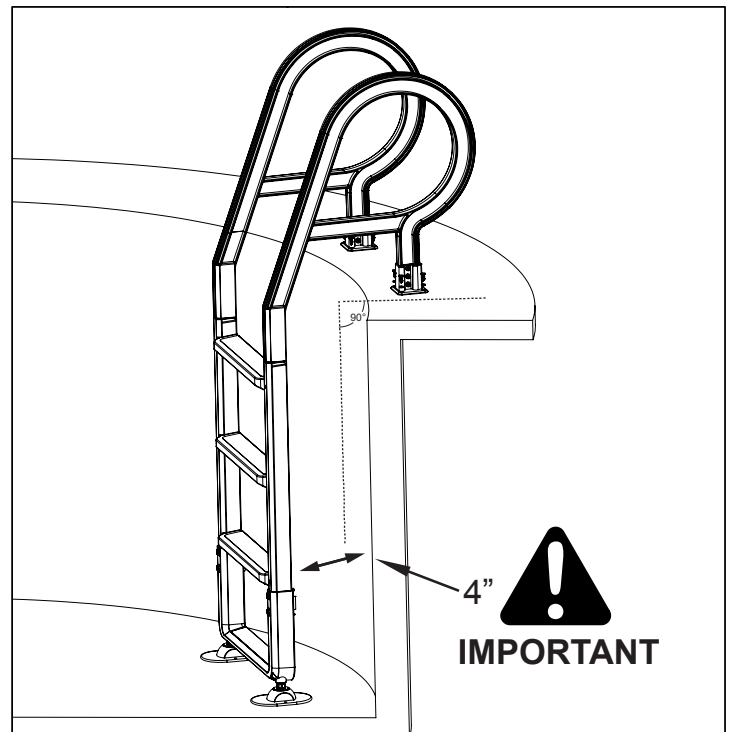

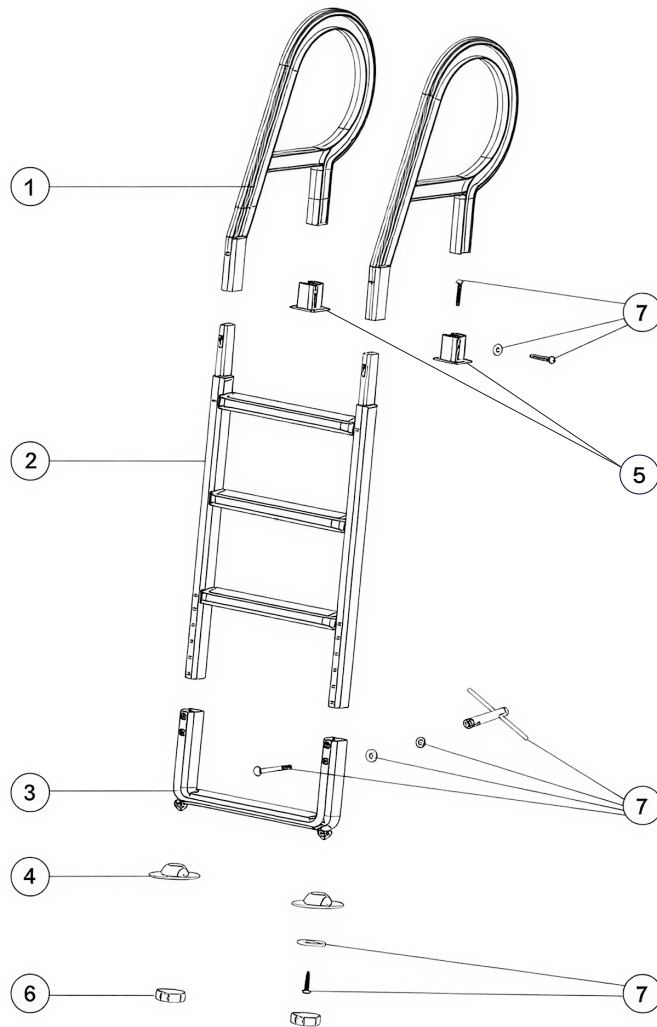

Ref. No.	Part No.	Description	Quantity
1	47153901001	Handrail	2
2	47153902001	Pedal Support	1
3	647153971000	Telescopic Support	1
4	47153906001	Base	2
5	47153905001	Armrest Holdeur	2
6	47153907001	Screw Cover	2
7	65862082000	Package of screw	1

Use only GoPool genuine replacement parts.

GoPool

Need parts or accessories ?
GoPool.com