

# IG2 Pump

Owner's Manual

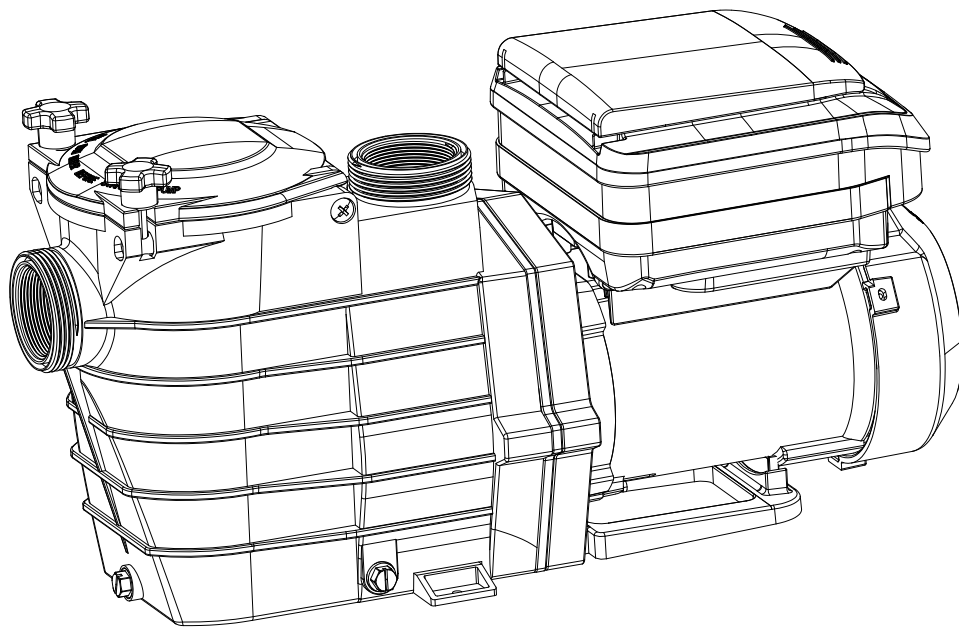

IG2-2022VS



Scan to register your  
product warranty

**GoPool**

## Warranty registration

Thank you for choosing GoPool! Register your product today to activate your warranty and get quick, hassle-free support when you need it.



Scan to register your product warranty



### WARNING

This equipment must be installed and serviced according to the information found in this manual. Improper installation can create hazards which could result in property damage, serious injury or death. Improper installation will void the warranty.

## Table of contents

Important safety instructions .....	1
Introduction .....	5
Using the drive keypad .....	7
Installation.....	10
Operation .....	14
Maintenance .....	21
Troubleshooting .....	26
Mobile App .....	29
Technical data .....	35
Pump structure & parts.....	36
Pump dimensions .....	37

Use only GoPool genuine replacement parts.



## IMPORTANT NOTICE

This guide provides installation and operation instructions for the Single Speed Pump. Consult us with any questions regarding this equipment.

### Attention Installer:

This guide contains important information about the installation, operation and safe use of this product. This information should be given to the owner and or operator of this equipment after installation or left on or near the heat pump.

### Attention User:

This manual contains important information that will help you in operating and maintaining this product. Please retain it for future reference.

**When installing and using this electrical equipment, basic safety precautions should always be followed, include the following:**

**DANGER:** Failure to follow all instructions and warnings can result in serious bodily injury or death. This pump should be installed and serviced only by a qualified pool service professional. Installers, pool operators and owners must read these warnings and all instructions in the owner's manual before using this pump. These warnings and the owner's manual must be left with the pool owner.

**⚠ Do not permit children to use this product.**

**CAUTION:** This pump is for use with permanent swimming pools and may also be used with hot tubs and spas if so marked. Do not use with storable pools. A permanently-installed pool is constructed in or on the ground or in a building such that it cannot be readily disassembled for storage. A storable pool is constructed so that it is capable of being readily disassembled for storage and reassembled to its original integrity.

## General Warnings

- Never open the inside of the drive motor enclosure. There is a capacitor bank that holds a 230 VAC charge even when there is no power to the unit.
- The pump is not submersible.
- The pump is capable of high flow rates; use caution when installing and programming to limit pumps performance potential with old or questionable equipment
- Code requirements for the electrical connection differ from state to state. Install equipment in accordance with the National Electrical Code and all applicable local codes and ordinances.
- Before servicing the pump; switch OFF power to the pump by disconnecting the main circuit to the pump.
- This appliance is not intended for use by persons (including children) of reduced physical, sensory or mental capabilities, or lack of experience and knowledge, unless they have been given supervision or instruction concerning the use of the appliance by a person responsible for their safety.



## Suction entrapment hazard

Stay off the main drain and away from all suction outlets! This pump is not equipped with safety vacuum release system (svrs) protection and does not protect against body or limb entrapments, disembowelments (when a person sits on a broken or uncovered pool drain) or hair entanglements.

This pump produces high levels of suction and creates a strong vacuum at the main drain at the bottom of the body of water. This suction is so strong that it can trap adults or children under water if they come in close proximity to a drain or a loose or broken drain cover or grate

The use of unapproved covers or allowing use of the pool or spa when covers are missing, cracked or broken can result if body or limb entrapment, hair entanglement, body entrapment, evisceration and/or death.

### The suction at a drain or outlet can cause:

- **Limb Entrapment:** When a limb is sucked or inserted into an opening resulting in a mechanical bind or swelling. This hazard is present when a drain cover is missing, broken, loose, cracked or not properly secured.
- **Hair Entanglement:** When the hair tangles or knots in the drain cover, trapping the swimmer underwater. This hazard is present when the flow rating of the cover is too small for the pump or pumps.
- **Body Entrapment:** When a portion of the body is held against the drain cover trapping the swimmer underwater. This hazard is present when the drain cover is missing, broken or the cover flow rating is not high enough for the pump or pumps.
- **Evisceration/Disembowelment:** When a person sits on an open pool (particularly a child wading pool) or spa outlet and suction is applied directly to the intestines, causing severe intestinal damage. This hazard is present when the drain cover is missing, loose, cracked, or not properly secured.
- **Mechanical Entrapment:** When jewelry, swimsuit, hair decorations, finger, toe or knuckle is caught in an opening of an outlet or drain cover. This hazard is present when the drain cover is missing, broken, loose, cracked, or not properly secured.

#### NOTE -

All suction plumbing must be installed in accordance with the latest national and local codes, standards and guidelines.

### To minimize the risk of injury due to suction entrapment hazard:

- A properly installed and secured ANSI/ASME A112.19.8 approved anti-entrapment suction cover must be used for each drain.
- Each suction cover must be installed at least three (3') feet apart, as measured from the nearest point to nearest point.
- Regularly inspect all covers for cracks, damage and advanced weathering.
- If a cover becomes loose, cracked, damaged, broken or is missing, replace with an appropriate certified cover.
- Replace drain covers as necessary. Drain covers deteriorate over time due to exposure to sunlight and weather.
- Avoid getting hair, limbs or body in close proximity to any suction cover, pool drain or outlet.
- Disable suction outlets or reconfigure into return inlets.



**⚠** The pump can produce high levels of suction within the suction side of the plumbing system. These high levels of suction can pose a risk if a person comes within the close proximity of the suction openings. A person can be seriously injured by this high level of vacuum or may become trapped and drown. It is absolutely critical that the suction plumbing be installed in accordance with the latest national and local codes for swimming pools.

A clearly labeled emergency shut-off switch for the pump must be in an easily accessible, obvious place. Make sure users know where it is and how to use it in case of emergency.

**CAUTION:** For Installation of Electrical Controls at Equipment Pad (ON/OFF Switches, Timers and Automation Load Center).

Install all electrical controls at equipment pad, such as on/off switches, timers, and control systems, etc., to allow the operation (startup, shut-down, or servicing) of any pump or filter so the user does not place any portion of his/her body over or near the pump strainer lid, filter lid or valve closures. This installation should allow the user enough space to stand clear of the filter and pump during system start-up, shut down or servicing of the system filter.

**⚠** Pumps improperly sized or installed or used in applications other than for which the pump was intended can result in severe personal injury or death. These risks may or severe injury or property damage caused by a structural failure of the pump or other system component.

**⚠ Hazardous pressure:**

Stand clear of pump and filter during start-up.

Circulation systems operate under high pressure. When any part of the circulating system (i.e., locking ring, pump, filter, valves, etc.) is serviced, air can enter the system and become pressurized. Pressurized air can cause the pump housing cover, filter lid, and valves to violently separate, which can result in severe personal injury or death. Filter tank lid and strainer cover must be properly secured to prevent violent separation. Stand clear of all circulation system equipment when turning on or starting up the pump. Before servicing equipment, make note of the filter pressure. Be sure that all controls are set to ensure the system cannot inadvertently start during service. Turn off all power to the pump.

**IMPORTANT:** Place filter manual air relief valve in the open position and wait for all pressure in the system to be relieved.

Before starting the system, fully open the manual air relief valve and place all system valves in the «open» position to allow water to flow freely from the tank and back to the tank. Stand clear of all equipment and start the pump.

**IMPORTANT:** Do not close the filter manual air relief valve until all pressure has been discharged from the valve and a steady stream of water appears. Observe filter pressure gauge and be sure it is not higher than the pre-service condition.



## General Installation Information

- All work must be performed by a qualified service professional and must conform to all national, state, and local codes.
- Install to provide drainage of compartment for electrical components.
- These instructions contain information for a variety of pump models and therefore some instructions may not apply to a specific model. All models are intended for use in swimming pool applications. The pump will function correctly only if it is properly sized to the specific application and properly installed.



## 01. Pump Features

- Extremely quiet operation
- 2 in. Plumbing for simple replacement.
- See-through strainer pot lid allows easy inspection of strainer basket.
- Self-priming for quick, easy start-up.

## 02. Motor Features

- High-Efficiency Permanent Magnet Motor
- Low noise
- Designed to withstand outdoor environment.
- Operates at lower temperatures due to high efficiency.
- Exceeds all Department of Energy and Energy Star requirements.
- Permanent-magnet, totally enclosed fan-cooled (TEFC) motor.
- IG2-2022VS HHP: 1.023 THP: 2.20 WEF: 7.8

## 03. Drive Features

The pump features a premium efficiency variable frequency drive that provides flexibility in terms of motor speed and duration settings.

**⚠** This pump is for use with 230 Vrms nominal, and in pool pump applications **ONLY**. Connection to the wrong voltage, or use in other applications may cause damage to equipment or personal injury.

The pump's drive controls the speed settings as well as run durations. The pump can operate at speeds ranging between 1000 and 3450 RPM and will operate within the voltage of 230 Vrms nominal at either 50 or 60Hz input frequency.



The pump is intended to run at the lowest speeds needed to maintain a sanitary environment and, at the same time, minimize energy consumption. Factors such as pool size, the presence of additional water features, type of chemicals used to maintain sanitary conditions, and local environmental factors will impact optimal programming to maximize energy conservation. Determining the optimal settings and programming for your pool may require some trial-and-error.

- Simple user interface
- UV and rain-proof enclosure
- Onboard time of day schedule
- Adjustable priming mode
- Programmable Quick Clean mode
- Pump alarm display and retention
- Accepts 230V, 50/60Hz input power
- Auto power limiting protection circuit
- 24hr. clock retention for power outages.

<b>Model</b>	<b>Voltage (VAC)</b>	<b>Max Amps</b>	<b>Input (Hz)</b>
IG2-2022VS	230	7,5	50/60



---

Before operating the pump for the first time, the pump's internal clock and operational schedules must be programmed. Refer to Setting the Clock and Programming Custom Schedules, for instructions regarding the programming of this pump for scheduled operation.

The pump can be programmed and controlled from the drive keypad. Pump features and settings are also accessed using this keypad.

**NOTE -**

- Functionality may vary based on other active features such as External Control Only Mode and/or Keypad Lockout.
- Always close the keypad cover after use. This will prevent damage to the keypad and other drive components.

**CAUTION:** Only press keypad buttons with your fingers. Using screwdrivers, pens or other tools to program the pump will damage the keypad.

**⚠** If power is connected to the pump motor, pressing any of the following buttons referred to in this section could result in the motor starting. Failure to recognize this could result in personal injury or damage to equipment.

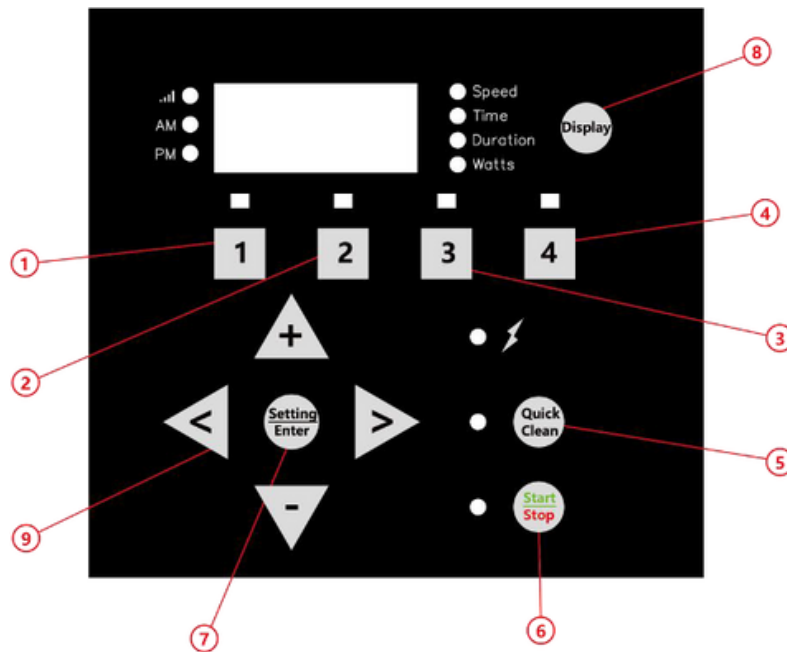

01. **Speed 1:** Press to select Speed 1 (2850 RPM), and the LED light indicates that the current speed 1 is running.
02. **Speed 2:** Press to select Speed 2 (1730 RPM). When the LED light is ON, it indicates that the current speed 2 is running.
03. **Speed 3:** Press to select Speed 3 (2300 RPM), and the LED light indicates that the current speed 3 is running.
04. **Speed 4:** Press to select Speed 4 (1150 RPM). When the LED is ON, the speed 4 is running.
05. Quick Clean key
06. Start/Stop key: Start or stop the pump. When the indicator light is on, it indicates that the pump is running or in the specified mode. When the light blinks, it means that the pump is not running and the current time has not reached the start time of the next scheduled mode.
07. When the frequency converter is shut down, enter the main menu directory.
08. Display button: used to switch between display contents when the water pump is running.
09. Arrow keys
  - **On key:** Increase the speed or time when adjusting.
  - **Under key:** Reduce the speed or time when adjusting.
  - **Left key:** Move cursor to left.

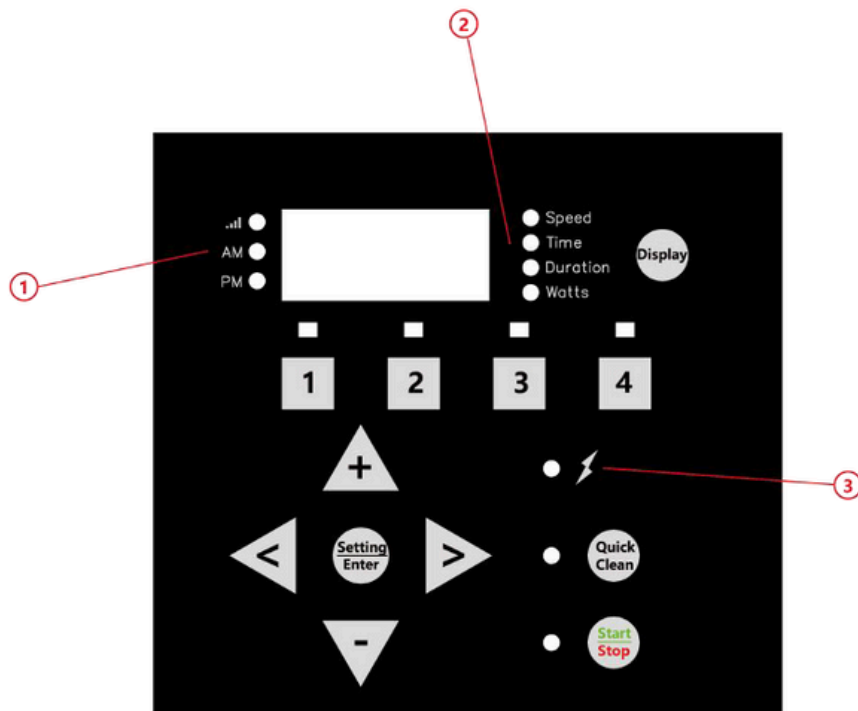

01. **Control panel digital tube:** used to view the current speed, time, duration, power, consumption, Bluetooth connection prompt and other functions.
02. **Display mode LED indicator light:** with the display button to display the corresponding LED, the information displayed on the digital tube corresponds to a specific point. Blinking indicates the current editable parameter.
03. **Power LED indicator:** When the LED light shines, it means that the pump has been energized.

Only a qualified plumbing professional should install the pump.

Refer to IMPORTANT SAFETY INSTRUCTIONS for additional installation and safety information.

## 01. Location

### NOTE -

Do not install this pump within an outer enclosure or beneath the skirt of a hot tub or spa. Ensure that the pump is mechanically secured to the equipment pad.

### Ensure the install location meets the following requirements:

- Install the pump as close to the pool or spa as possible. To reduce friction loss and improve efficiency, use short, direct suction and return piping.
- Install a minimum of 5 ft. (1.5 m) from the inside wall of the pool and spa. Canadian installations require a minimum of 9.8 ft. (3 m) from the inside wall of the pool.
- Install the pump a minimum of 3 ft. (0.9 m) from the heater outlet.
- Do not install the pump more than 5 ft. (1.5 m) above the water level.
- Install the pump in a well-ventilated location protected from excess moisture (i.e., rain gutter downspouts, sprinklers, etc.).
- Install the pump with a rear clearance of at least 3 in. (7.6 cm) so that the motor can be removed easily for maintenance and repair. See Figure 1.

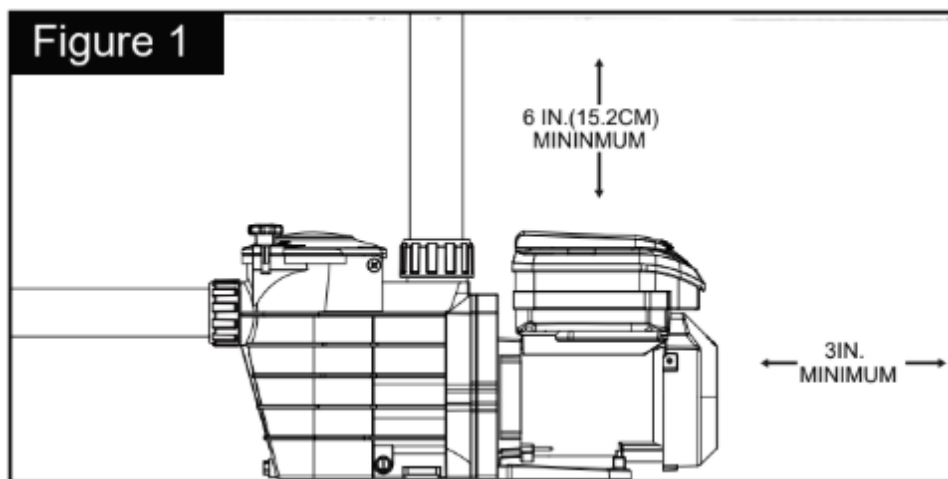

## 02. Piping

- For improved pool plumbing, it is recommended to use a larger pipe size.
- Piping on the suction side of the pump should be the same or larger than the return line diameter.
- Plumbing on the suction side of the pump should be as short as possible.
- For most installations, it is recommended to install a valve on both the pump suction and return lines so that the pump can be isolated during routine maintenance. However, we also recommend that a valve, elbow or tee installed in the suction line should be no closer to the front of the pump than five (5) times the suction line diameter. See Figure 2.

**Example:** A 2.5 in. pipe requires a 12.5 in. (31.8 cm) straight run in front of the suction port. This will help the pump prime faster and last longer.

**NOTE -**  
DO NOT install 90° elbows directly into the suction or discharge ports.

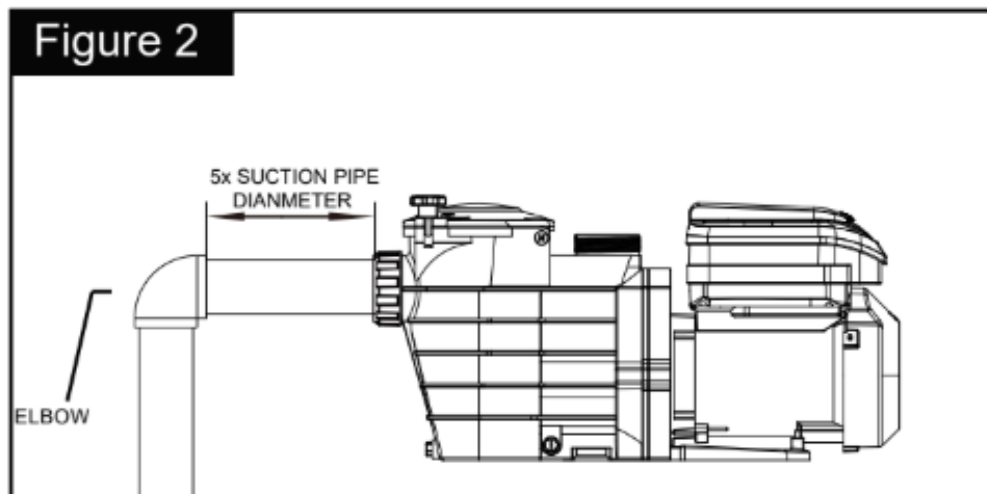

## 03. Fittings and Valves

- Do not install 90° elbows directly into suction port.
- Flooded suction systems should have gate valves installed on suction and discharge pipes for maintenance; however, the suction gate valve should be no closer than five times the suction pipe diameter as described in this section.
- Use a check valve in the discharge line when using this pump for any application where there is significant height to the plumbing after the pump.
- Be sure to install check valves when plumbing in parallel with another pump. This helps prevent reverse rotation of the impeller and motor.



## 04. Electrical Installation

### Risk of electrical shock or electrocution.

The pump must be installed by a licensed or certified electrician or a qualified service professional in accordance with the National Electrical Code and all applicable local codes and ordinances. Improper installation will create an electrical hazard which could result in death or serious injury to users, installers, or others due to electrical shock, and may also cause damage to property.

Always disconnect power to the pump at the circuit breaker before servicing the pump. Failure to do so could result in death or serious injury to service people, pool users or others due to electric shock and/or property damage.

Read all servicing instructions before working on the pump.

The pump accepts 230V, 50 or 60 Hz single-phase input power. Power connections are capable of handling up to 8 AWG solid or stranded wire.

## 05. Wiring

- Ensure all electrical breakers and switches are turned off before wiring the motor.

### Stored charge

Wait at least 5 minutes before servicing.

- Ensure supply voltage meets the requirements listed on the motor nameplate.
- For wiring sizes and general requirements, follow specifications defined by the current National Electric Code and any local codes. When in doubt, use a heavier gauge (larger diameter) wire.
- Ensure all electrical connections are clean and tight.
- Cut all wiring to the appropriate length so they do not overlap or touch when connected to terminals.
- **ALWAYS** reinstall the drive lid after electrical installation or before leaving the pump unsupervised during servicing. This will prevent rainwater, dust, or other foreign matter from accumulating in the drive.

#### **NOTE -**

Ensure wires are not pinched between the drive body and lid.

## 06. Grounding

- Permanently ground the motor using the Grounding Terminal inside the drive wiring compartment. Refer to the current National Electrical Code and any local codes for wire size and type requirements. Ensure the ground wire is connected to an electrical service ground.

## 07. Bonding

- Using the Bonding Lug located on the side of the motor, bond the motor to all metal parts of the pool structure, electrical equipment, metal conduit, and metal piping within 5 ft. (1.5 m) of the inside walls of the swimming pool, spa, or hot tub in accordance with the current National Electrical Code and any local codes.
- Solid copper bonding conductor of 8 AWG or larger is required. For Canadian installations, 6 AWG or larger solid copper bonding conductor is required.

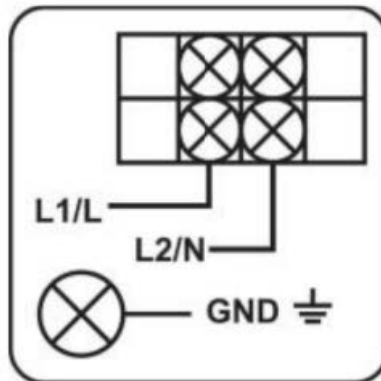



Before operating the pump for the first time, the pump's internal clock and operational schedules must be programmed by following the steps in this manual.

Refer to **Setting the Clock** below and **Programming Custom Schedules**, for instructions regarding the programming of this pump for scheduled operation.

**NOTE -**  
When programming a new schedule, please program the start time of speed 1-4 according to the time sequence of one day.

## 01. Setting the Clock

When power is first connected to the pump, the clock will blink to indicate that it has not been set. Custom schedules are based on this clock setting, so the clock must be set first.

- Press Setting.
- Use «+» and «-» to program the current time.
- Use «<» and «>» to move the modify cursor.

**NOTE -**  
In the 12-hour time format, AM/PM will display on the left.

## 02. Using the Default Schedule

The default schedule is designed to provide sufficient daily turnover for a typical pool.

### The default cycle is 22 hours a day

The program	Start up time	Time of operation	Default speed
Speed 1	8:00 AM (8:00) (adjustable)	2H (adjustable)	2400 RPM (adjustable)
Speed 2	10:00 AM (10:00) (adjustable)	10H (adjustable)	1500 RPM (adjustable)
Speed 3	8:00 PM (20:00) (adjustable)	2H (adjustable)	2000 RPM (adjustable)
Speed 4	10:00 PM (22:00) (adjustable)	8H (adjustable)	1000 RPM (adjustable)

**SAVE TIME!  
Watch the tutorial!**





The default schedule will operate as follows:

- **SPEED 1** will begin at 8:00am and run at 2850 RPM for a duration of 2 hours.
- **SPEED 2** will begin at 10:00am and run at 1730 RPM for a duration of 10 hours.
- **SPEED 3** will begin at 8:00pm and run at 2300 RPM for a duration of 2 hours.
- **SPEED 4** will begin at 10:00pm and run at 1150 RPM for a duration of 8 hours.
- At the end of speed 4, the pump will stop running for 2 hours and then run speed 1 again. Because the factory is set to run continuously for 22 hours every day until the user changes the default schedule.

**NOTE -**

The Start/Stop button must be pressed, and the Start/Stop LED illuminated, for the pump to run.

### 03. Programming Custom Schedules

To customize your pump's schedule, the pump must be stopped. Ensure that the Start/Stop LED is not illuminated. When programming, the LED next to the parameter you are editing will blink.

- **"Speed"** - Run Speed
- **"Time"** - Start Time
- **"Duration"** - Run Time

#### Speed Priorities (Non-External Control)

For schedule duration settings, SPEEDs are prioritized as follows: SPEED 1 -> SPEED 2 -> SPEED 3 -> SPEED 4. SPEED 1 is the highest priority, while SPEED 4 is the lowest.

The drive has priority Settings, as shown in the following table.

Example: Starting Schedule (Before Adjustment)

- **SPEED 1** start time = 8:00AM, duration = 6 hours
- **SPEED 2** start time = 9:00AM, duration = 1 hour
- **SPEED 3** start time = 10:00AM, duration = 1 hour
- **SPEED 4** start time = 2:00PM, duration = 1 hour

In this way, according to the priority, the water pump will run the SPEED 1 mode from 8:00 a.m. to 2:00 p.m. (skip the SPEED 2 and 3 modes in the middle, because SPEED 2 and 3 have been included in the SPEED 1 operation period), and the SPEED 4 mode will run from 2:00 p.m. to 3:00 p.m.

End Schedule (After Adjustment)

- **SPEED 1** start time = 8:00AM, duration = 6 hours
- **SPEED 4** start time = 2:00PM, duration = 1 hour

## To program a custom schedule :

- 1) Press Start/Stop to stop the pump.
- 2) Press "1". The SPEED 1 LED and the "Speed" parameter LED will blink while editing.

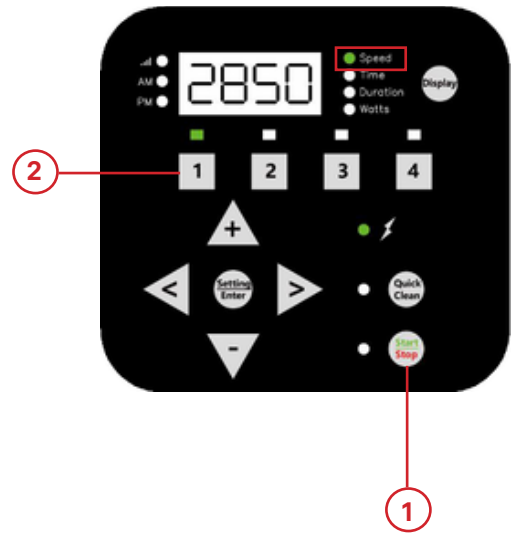

- 3) Use "+" and "-" to adjust the speed in RPM for SPEED 1, use the "<" and ">" to move the cursor.

### NOTE -

The speed adjustment stepping is 100/10/1rpm.

- 4) Press "1". The SPEED 1 start time will display. The "Time" parameter LED will begin to blink.

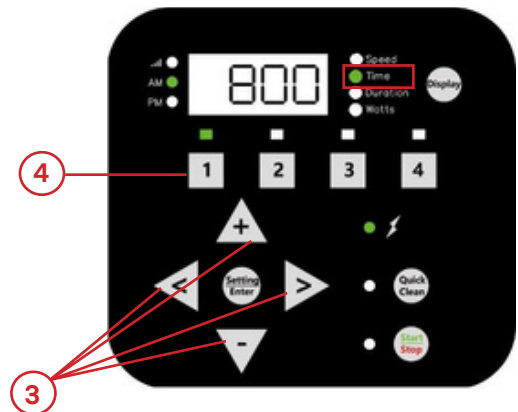

- 5) Use "+" and "-" to adjust the SPEED 1 start time. Use the "<" and ">" to move the cursor.

### NOTE -

The start time adjustment stepping is 1 hour/10 min/1 min.

- 6) Press "1". SPEED 1 duration will display. The "Duration" parameter LED will begin to blink.

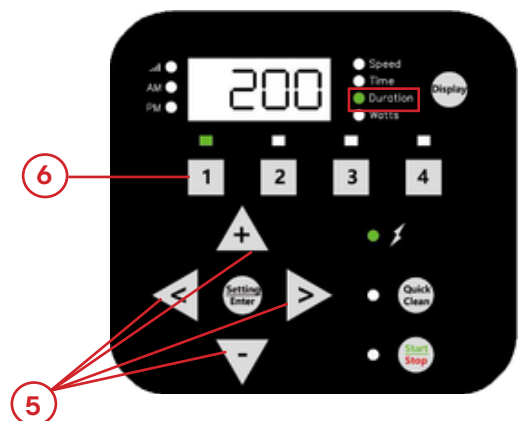



7) Use "+" and "-" to adjust the duration of SPEED 1 in hours and minutes.

**NOTE -**

If the duration is set to 0 hours, the pump will not run this program segment during this period.

8) SPEED 1 is now successfully programmed.

**NOTE -**

Pressing "1" will continue to cycle through these parameters, but changes are immediately saved as they are adjusted.

9) Press "2". The SPEED 2 LED and "Speed" parameter LED will blink while editing.

10) Use "+" "-" "<" and ">" to adjust the speed in RPM for SPEED 2.

11) Press "2". The SPEED 2 duration will display.

12) Use "+" "-" "<" and ">" to adjust the duration of SPEED 2 in hours and minutes.

13) Repeat steps 9-12 to program SPEED 3, 4, and QUICK CLEAN.

14) Press Start/Stop and ensure the Start/Stop LED is illuminated. The pump is now active and will run the programmed schedule.

**NOTE -**

If the pump was stopped using the **Start/Stop** button, the pump will not run until the **Start/Stop** button is pressed again. If the Start/Stop LED is illuminated, the pump is on and will run the programmed schedule.

## 04. Operating the Pump While Running

**CAUTION:** If power is connected to the pump, pressing any of the following buttons referred to in this section could result in the motor starting. Failure to recognize this could result in personal injury or damage to equipment.

Pressing the Display button will cycle through the current parameters:

- **Speed** – current run speed
- **Time** – current time of day
- **Duration** – amount of time remaining at current run speed
- **Watts** – watts currently being consumed

Pressing any of the **SPEED** Buttons ("1", "2", "3", "4" or **Quick Clean**) while the pump is running will act as a temporary override. The pump will run the speed and duration programmed for that button. Once completed, the pump will return to the appropriate point in the programmed schedule.

**NOTE -**

If schedule speeds are adjusted while the pump is running, the pump will run the entered speed for the rest of the program's duration, but will not save the adjustments.



## 05. Priming

**CAUTION:** This pump is shipped with Priming mode **ENABLED**. The pump will ramp up to 3200 RPM when the pump is initially started.

Before turning the pump ON:

- 1) Open filter air relief valve.
- 2) Open necessary valves.
- 3) Ensure return line is completely open and clear of any blockages.
- 4) Ensure pump is filled with water.
- 5) Stand clear of the filter or other pressurized vessels.

**⚠ DO NOT** run the pump dry. The shaft seal will be damaged, and the pump will start leaking. If this occurs, the damaged seal must be replaced.

ALWAYS maintain proper water level in your pool (halfway up the skimmer opening). If the water level falls below the skimmer opening, the pump will draw air through the skimmer, losing the prime and causing the pump to run dry, resulting in a damaged seal. Continued operation in this manner could cause a loss of pressure, resulting in damage to the pump body, impeller, and seal and may cause property and personal injury.

When the pump starts, the start will run automatically in addition to running a quick cleaning cycle. The default startup speed is 2400 RPM. The pump will slowly rise up to 3200 RPM and will last 5 minutes. The drive will display the remaining time.

**NOTE -**

After the pump's priming cycle has completed, if there is time remaining on the control system's priming timer, the pump will run the control system priming speed until the timer expires.

During boot, the boot speed can be adjusted between 3200 RPM and 3450 RPM with «+» and «-».

**NOTE -**

The first startup starts with a countdown of 5 minutes. You can press SPEED 1, 2, 3, 4 to pre-exit the self-priming. If the pump is started again, the pump will decide whether to self-prime based on the current environment. The judgment time is 20 seconds.

Priming time can change based on local environmental conditions such as water temperature, atmospheric pressure, and your pool's water level. All of these things should be taken into consideration when setting the priming speed. Test and verify priming speeds more than once, letting the water drain from the system in between each test.

**NOTE -**

To prevent air from entering the system, the pump strainer pot should always be filled with water up to the bottom of the suction port.

## 06. Programming Quick Clean

The pump is equipped with a Quick Clean feature, which can be engaged to temporarily run at higher or lower speeds ranging from 1700 to 3450 RPM.

At the end of a Quick Clean cycle, the pump will automatically return to the appropriate point in its programmed schedule.

### To program quick clean :

- 1) Press **Start/Stop** to stop the pump.
- 2) Press **Quick Clean**. The Quick Clean LED and "Speed" parameter LED will blink while editing.

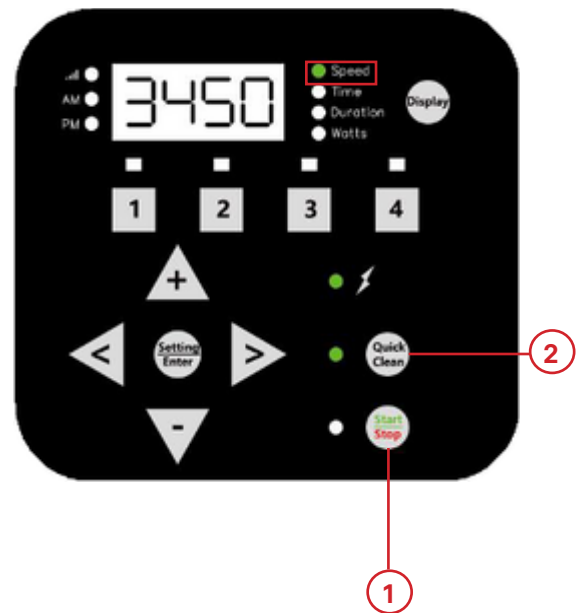

- 3) Use "+" and "-" to adjust the Quick Clean speed in RPM, use the "<" and ">" to move the cursor.

**NOTE -**  
The speed adjustment stepping is 100/10/1rpm.

- 4) Press Quick Clean. The Quick Clean duration will display. The "Duration" parameter LED will blink while editing.
- 5) Use "+" and "-" to adjust the Quick Clean duration in hours and minutes, use the "<" and ">" to move the cursor.

**NOTE -**  
The duration adjustment stepping is 1 hour/10 min.  
The duration can be adjusted from 10 minutes to 24 hours.  
Quick Clean duration does not affect the start.

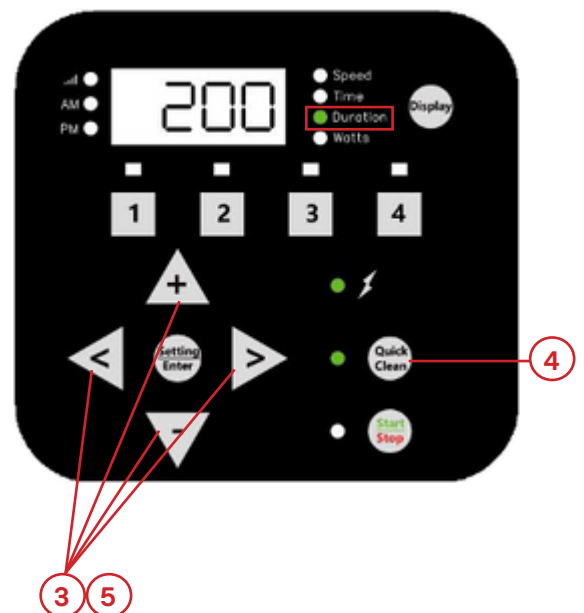



## 07. **Factory Reset**

The drive can be reset to factory settings if necessary. A Factory Reset will erase all programmed settings and schedules, except for the time of day. Be sure that it is necessary before performing a Factory Reset, as the results are immediate.

### TO PERFORM A FACTORY RESET:

- 1) If the pump is running, press the Start/Stop button to stop the pump.
- 2) Press and hold "1", "2" for 3 seconds.
- 3) If the factory reset is successful, you will hear a 3-second prompt tone.
- 4) Reprogram the schedule and priming speed as described in the previous sections. The pump must be turned back on with the Start/Stop button before it will run again. The pump will run the programmed schedule upon initial start-up.



**⚠ DO NOT** open the strainer pot if the pump fails to prime or if the pump has been operating without water in the strainer pot. Pumps operated in these circumstances may experience a build-up of vapor pressure and may contain scalding hot water. Opening the pump may cause serious personal injury. To avoid the possibility of personal injury, make sure the suction and discharge valves are open and the strainer pot temperature is cool to touch, then open with extreme caution.

Always disconnect power to the pump at the circuit breaker and disconnect the digital input cable before servicing the pump. Failure to do so could result in death or serious injury to service people, users, or others due to electric shock. Read all servicing instructions before working on the pump.

**CAUTION :** To prevent damage to the pump and for proper operation of the system, clean the pump strainer and skimmer baskets regularly.

## 01. Cleaning the pump strainer basket

The strainer pot is located at the front of the pump and houses the pump strainer basket.

The strainer basket can be viewed through the strainer pot lid and should be visually inspected at least once a week. Regularly emptying and cleaning the strainer basket will lead to higher filter and heater efficiency and prevent unnecessary stress on the pump motor.

### To clean the strainer basket:

- 1) Press **Start/Stop** to stop the pump and shut off all electrical power to the pump at the circuit breaker.
- 2) Open the filter air relief valve and relieve all pressure from the filtration system.
- 3) Turn the strainer pot lid counter-clockwise and remove it from the pump.
- 4) Remove debris and rinse out the basket. Replace the basket if it is cracked or damaged.
- 5) Place the basket into the strainer pot. Ensure the notch in the bottom of the basket is aligned with the rib in the bottom of the strainer pot.
- 6) Fill the strainer pot with water up to the inlet port.
- 7) Clean the lid O-ring and sealing surface of the strainer pot.

#### **NOTE -**

It is important to keep the lid O-ring clean and well-lubricated.

- 8) Reinstall the lid by placing it onto the strainer pot and tightening clockwise until the lid handles are horizontal.

#### **NOTE -**

Ensure the lid O-ring is properly placed and is not being pinched between the lid and strainer pot. Ensure that the side of the lid marked «Front» is positioned at the front of the pump.

- 9) Open the filter air relief valve and stand clear of the filter.
- 10) Reestablish electrical power to the pump at the circuit breaker and start the pump.
- 11) When a steady stream of water flows from the filter air relief valve, close the valve.



## 02. Motor care

### Protect from Heat

- 1) Shade the motor from the sun.
- 2) Any enclosure must be well ventilated to prevent overheating.
- 3) Provide ample cross ventilation.

### Protect Against Dirt

- 1) Protect from any foreign matter.
- 2) Do not store (or spill) chemicals on or near the motor.
- 3) Avoid sweeping or stirring up dust near the motor while it is operating.
- 4) If the motor has been damaged by dirt, it may void the motor warranty.
- 5) Clean the lid, O-ring, and sealing surface of the strainer pot regularly.

### Protect Against Moisture

- 1) Protect from splashing or sprayed water.
- 2) Protect from extreme weather.
- 3) If motor internals have become wet, let them dry before operating. Do not allow the pump to operate if it has been flooded.
- 4) If the motor has been damaged by water, it may void the motor warranty.

### **This system operates under high pressure.**

When any part of the circulating system is serviced, air can enter the system and become pressurized. Pressurized air can cause the lid to separate, which can result in serious injury, death, or property damage. To avoid this potential hazard, follow the above instructions.

Refer to the **Motor/Hydraulics Assembly Diagram**, on the next page, for a parts breakdown of the pump.

 Always disconnect power to the pump at the circuit breaker before servicing the pump. Failure to do so could result in death or serious injury to service people, users, or others due to electric shock. Read all servicing instructions before servicing the pump.

**DO NOT** open the strainer pot if the pump fails to prime or if the pump has been operating without water in the strainer pot. Pumps operated in these circumstances may experience a build-up of vapor pressure and may contain scalding hot water. Opening the pump may cause serious personal injury. To avoid the possibility of personal injury, make sure the suction and discharge valves are open and the strainer pot temperature is cool to touch, then open with extreme caution.



## 03. Pump disassembly

Tools required:

- Adjustable wrench
- #2 Phillips screwdriver
- Flat blade screwdriver

To disassemble the pump:

- 1) Press **Start/Stop** to stop the pump and disconnect all power to the pump at the circuit breaker.
- 2) Disconnect any digital inputs or communication cables from the pump (if connected).
- 3) Close all valves in suction and discharge lines.
- 4) Relieve all system pressure at the filter's air relief valve.
- 5) Remove both drain plugs from the bottom of the strainer pot.
- 6) Using an adjustable wrench, remove the two strainer pot through-bolts and nuts securing the motor/hydraulics assembly to the strainer pot.
- 7) Using an adjustable wrench, open-end wrench, or socket, remove the four remaining strainer pot bolts.
- 8) **GENTLY** separate the motor/hydraulics assembly from the strainer pot.
- 9) Using an adjustable wrench, remove the two screws securing the diffuser to the seal plate. Remove the diffuser.
- 10) Using an adjustable wrench, hold the motor shaft in place at the rear of the motor. This will prevent the motor shaft from spinning while removing the impeller and impeller screw.
- 11) Continue to hold the motor shaft in place. Remove the impeller screw and washer clockwise using a #2 Phillips screwdriver.
- 12) Remove the impeller counter-clockwise by hand.
- 13) Using a 9/16 in. wrench, remove the four (4) bolts securing the seal plate to the motor.
- 14) Remove the seal plate from the motor/drive assembly.

## 04. Pump reassembly

- 1) Place the seal plate onto the motor assembly, ensuring the side marked "UP" is at the top.
- 2) Using an adjustable wrench, reinstall the motor/seal plate bolts in a criss-cross pattern. Secure the seal plate to the motor with the four motor bolts. Tighten to 70–80 in-lbs. (81–92 kg/cm).
- 3) Using an adjustable wrench, hold the motor shaft in place at the rear of the motor. This will prevent the motor shaft from spinning while reinstalling the impeller and impeller screw.
- 4) Continue to hold the motor shaft in place and reinstall the impeller onto the motor shaft clockwise hand tight.
- 5) Continue to hold the motor shaft in place and reinstall the impeller screw and washer. Tighten to 25 in-lbs. (29 kg/cm).

**NOTE -**

The impeller screw is reverse threaded and tightens counter-clockwise.

- 6) Reinstall the diffuser onto the seal plate using the two diffuser screws.
- 7) Inspect the diffuser seal and seal plate gasket for damage and replace if necessary. Grease both before continuing.
- 8) Using an adjustable wrench, secure the strainer pot to the motor/hydraulics assembly with the six strainer pot bolts and washers.

**NOTE -**

Do not tighten the two through-bolts until all six bolts are in place and finger tightened. Tighten in a criss-cross pattern to 110 in-lbs (127 kg/cm). Ensure the seal plate gasket is not pinched between the strainer pot and motor assembly.

- 9) Reinstall both drain plugs into the bottom of the strainer pot.
- 10) To restart the pump, continue to Restarting the Pump.

## 05. Restarting the Pump

If the pump is installed below the water level of the pool, close return and suction lines prior to opening the strainer pot on the pump. Make sure to re-open valves prior to operating.

**CAUTION : DO NOT** run the pump dry. The shaft seal will be damaged and require replacement. **ALWAYS** maintain proper water level in your pool (halfway up the skimmer opening). If the water level falls below the skimmer opening, the pump will draw air through the skimmer, lose prime, and cause the pump to run dry. Continued operation in this manner could cause a loss of pressure, damage the pump and/or property or personal injury.

### To prime the pump:

- 1) Press **Start/Stop** to stop the pump and disconnect all power to the pump at the circuit breaker.
- 2) Relieve all pressure from the filtration system at the filter air relief valve.
- 3) Remove the strainer pot lid by twisting it in a counter-clockwise direction.
- 4) Fill the strainer pot up to the inlet port with water.
- 5) Place the lid onto the strainer pot, then turn clockwise to lock in place.

**NOTE -**

The lid is properly locked when the handles are nearly perpendicular to the pump body.

- 6) Return power to the pump at the circuit breaker.
- 7) Open the filter air relief valve.
- 8) Stand clear of the filter and press the **Start/Stop** button to start the pump.
- 9) Bleed air from the filter air relief valve until a steady stream of water appears, then close the relief valve.
- 10) The pump will run a priming cycle and, if successful, begin normal operation.



## 06. Winterizing

You are responsible for determining when freezing conditions may occur. If freezing conditions are expected, take the following steps to reduce the risk of freeze damage. **Freeze damage is not covered under warranty.**

In mild climate areas, when temporary freezing conditions may occur, run your filtering equipment all night to prevent freezing.

To prevent freeze damage:

- 1) Press **Start/Stop** to stop the pump and disconnect all power to the pump at the circuit breaker.
- 2) Disconnect all power to the pump at the circuit breaker.
- 3) Relieve all pressure from the filtration system at the filter air relief valve.
- 4) Remove both drain plugs from the bottom of the strainer pot and drain the pump. Store the plugs in the strainer basket.
- 5) Cover the motor to protect it from severe rain, snow, and ice.

**NOTE -**

Do not wrap the motor with plastic or other airtight materials during winter storage. Never cover the motor when operating or expecting operation.



**⚠** Diagnosing certain symptoms may require interaction with, or close proximity to, components that are energized with electricity. All servicing should be performed by a qualified service professional. Contact with electricity can cause death, personal injury, or property damage.

<b>Problem</b>	<b>Possible cause</b>	<b>Solution</b>
<b>Pump failure</b>	Pump will not prime – Air in suction line or pump	<ol style="list-style-type: none"><li>1. Inspect suction line plumbing and valve(s) for damage or loose connections.</li><li>2. Ensure the strainer pot lid is sealing properly. Verify lid O-ring is in place.</li><li>3. Ensure proper pool water level and water is available to the skimmer.</li></ol>
	Pump will not prime – Not enough water	<ol style="list-style-type: none"><li>1. Ensure suction line and pump strainer pot are full of water.</li><li>2. Ensure suction line valve is working and open (some systems do not have valves).</li><li>3. Ensure proper pool water level and water is available to the skimmer.</li></ol>
	Strainer basket excessively dirty or full.	Clean strainer basket. See Cleaning the Pump Strainer Basket.
	Strainer pot O-ring is damaged.	Inspect strainer pot O-ring for damage. Replace if necessary.
<b>Reduced capacity and/or head</b>	Air in suction line or pump.	<ol style="list-style-type: none"><li>1. Inspect suction line plumbing and valve(s) for damage or loose connections.</li><li>2. Ensure the strainer pot lid is sealing properly. Verify lid O-ring is in place.</li><li>3. Ensure proper pool water level and water is available to the skimmer</li></ol>
	Clogged impeller	Disassemble pump and remove debris from impeller.
	Strainer basket excessively dirty or full	Clean strainer basket. See Cleaning the Pump Strainer Basket.
<b>Pump fails to start</b>	Mains voltage is not present	<ol style="list-style-type: none"><li>1. Replace fuse, reset breaker.</li><li>2. Tighten mains wire connections.</li></ol>
	Motor is locked	Disassemble pump and attempt to rotate motor shaft by hand to remove any blockage.
	Motor shaft is damaged	Replace pump.



<b>Problem</b>	<b>Possible cause</b>	<b>Solution</b>
<b>Pump runs then stops</b>	Over temperature FAULT	Ensure motor fan cover at the rear of the motor is free of dirt and debris. Use compressed air to clean.
	Over current FAULT	Pump will automatically restart after one (1) minute.
<b>Pump is noisy</b>	Debris in contact with fan.	Ensure motor fan cover at the rear of the motor is free of dirt and debris. Use compressed air to clean.
	Strainer basket excessively dirty or full.	Clean strainer basket.
	Loose mounting.	Ensure mounting bolts and pump bolts are tight.
<b>Pump runs without flow</b>	Impeller is loose	Ensure fan at the rear of the pump is spinning. If so, disassemble pump and ensure impeller is correctly installed.
	Air in suction line or pump	<ol style="list-style-type: none"><li>1. Inspect suction line plumbing and valve(s) for damage or loose connections.</li><li>2. Ensure the strainer pot lid is sealing properly. Verify lid O-ring is in place.</li><li>3. Ensure proper pool water level and water is available to the skimmer.</li></ol>
	Clogged or restricted plumbing	<ol style="list-style-type: none"><li>1. Inspect for and clear any blockage in the strainer pot or suction line.</li><li>2. Inspect for blockage in discharge piping including partially closed valve or dirty pool filter.</li></ol>



## 01. Alarms and Fault Codes

If an alarm is triggered, the drive will display a fault code text, and the pump will stop running. Disconnect power to the pump and wait until the keypad LEDs have all turned off, then reconnect power. If the error continues to appear after power is reconnected, proper troubleshooting will be required. Use the error description table below to begin troubleshooting.

Fault Code	Description
1	Blocked or motor wire short circuit or high temperature rise
2, 4, 6	The input voltage is too high
8	The input voltage is too low
16, 128	Motor fails to start normally
256	Motor phase loss or the motor and driver are not connected well
300	No load
301	Overtemperature

**POWER OUT FAILURE** – Incoming supply voltage is less than 190 VAC, or the controller is disturbed, and the input voltage exceeds the limit value.

**16, 128 – Motor fails to start normally:** The motor is stuck, or the ground wire of the motor is not properly connected, or the driver is not correctly installed on the motor.

**300 – No load:** Water may not be absorbed.

**301 – Overtemperature:** The temperature of components inside the driver exceeds the limit.

It is possible to have two or more abnormalities at the same time. For example, when the motor stops abnormally, error code 7 is displayed, indicating the superposition of error codes 1, 2, and 4.



## 01. Download the "Smart Life" APP

Please scan the QR code below the surface with your mobile phone, download the "SmartLife" APP, and select the corresponding operating system (Android/IOS).



## 02. Add equipment

1) In the case of the mobile phone and the water pump sharing the same WiFi, open the APP to connect the PUMP power supply, and the prompt of adding PUMP will pop up on the interface. You can also click «+» and select «Add Device» to increase the water pump equipment to be added.

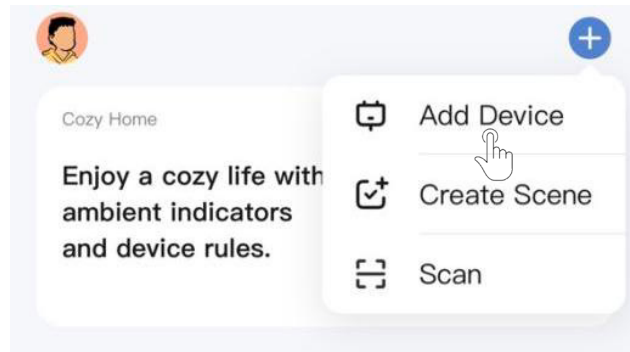
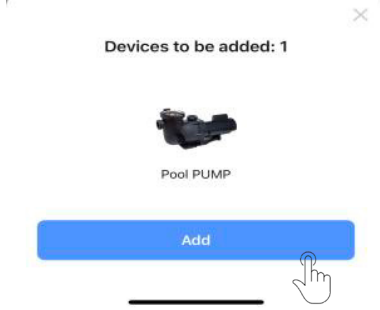
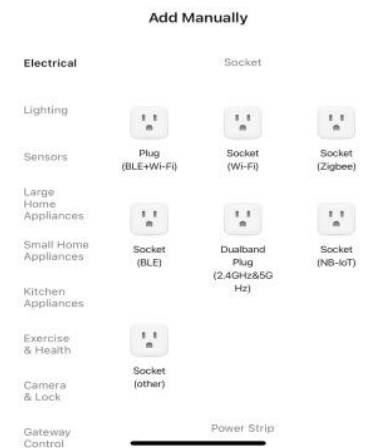
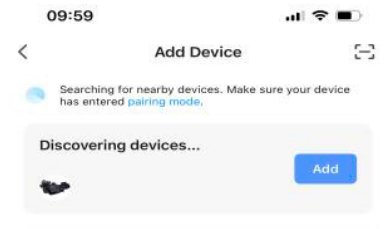
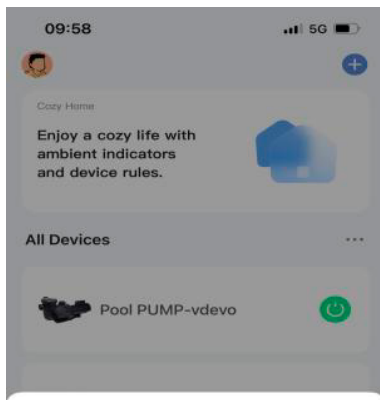

2) Enter the WIFI password in the WIFI interface to add WIFI for PUMP, and click 'Done' to add.

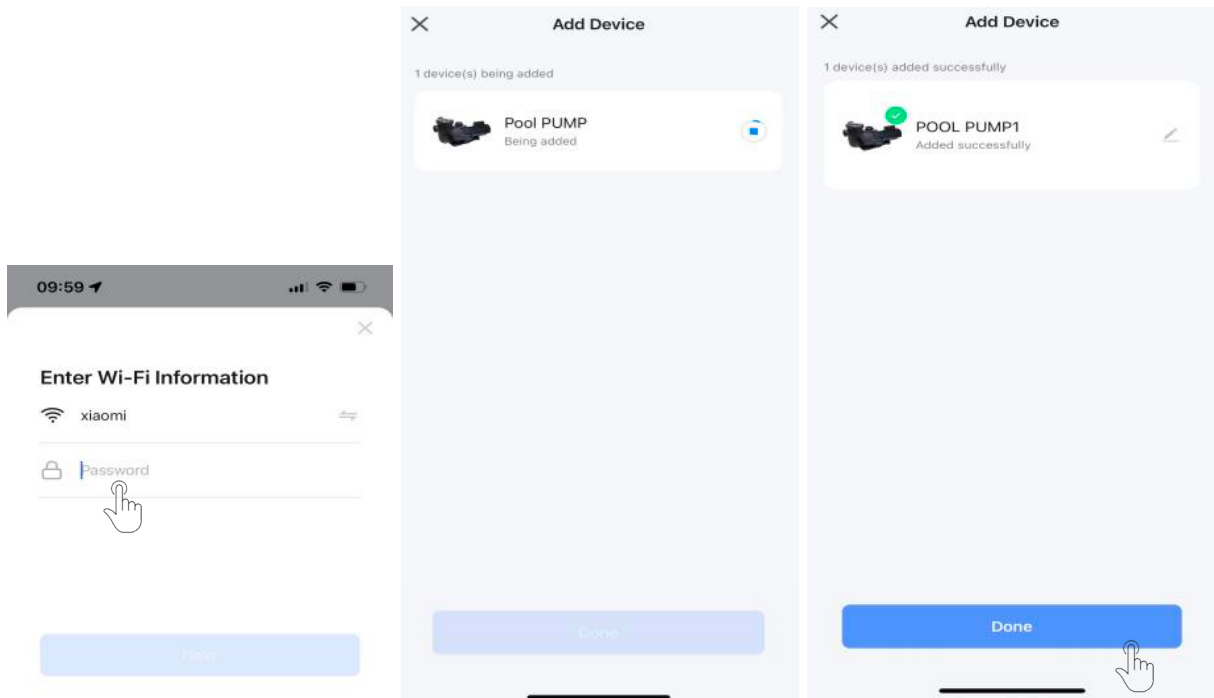

## 01. Use equipment

1) Introduction of the interface:

The name of the pump (editable)

Speed zone Can be manually adjusted

Pump running state (Off/Running)

APP function operation area

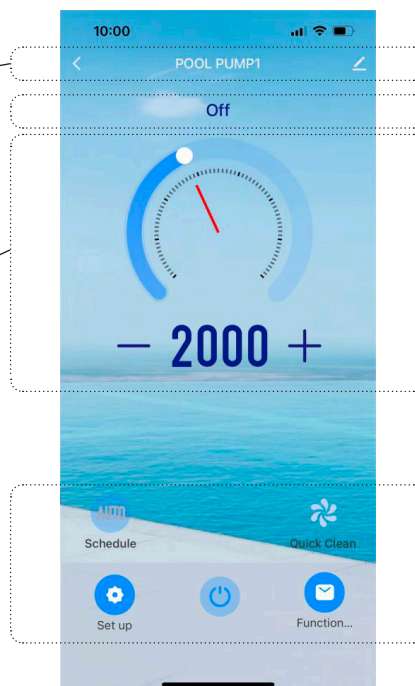

Next →

## 2) Operation instructions:

- Click  "Open Key" to start or stop running the water pump. The AUTO icon is illuminated and performs a factorymode operation.

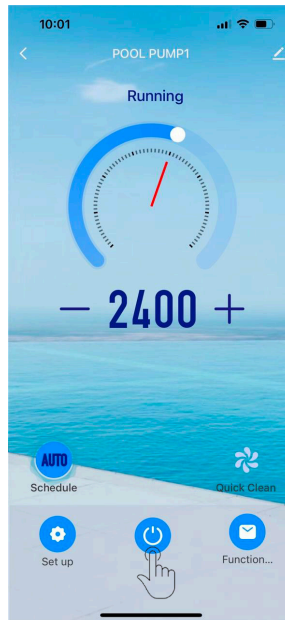

## 3) Schedule mode setting:

- Click "Set up" to enter the setting interface, click Mode speed to set the running speed of Pump in each stage, and click "confirm" to confirm after the modification

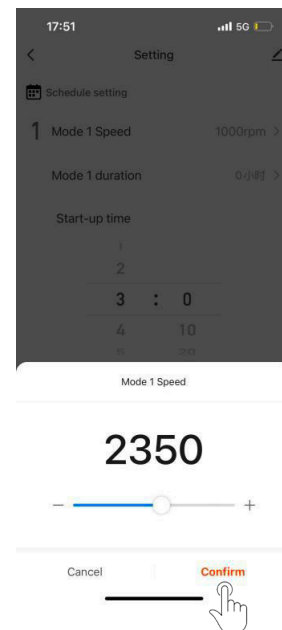
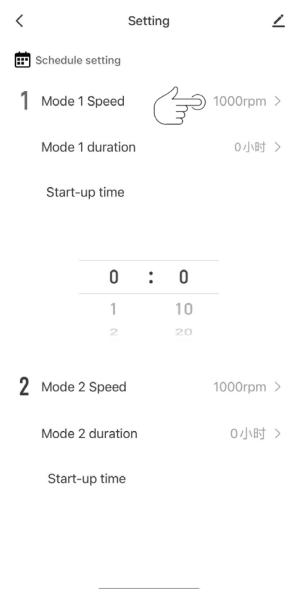
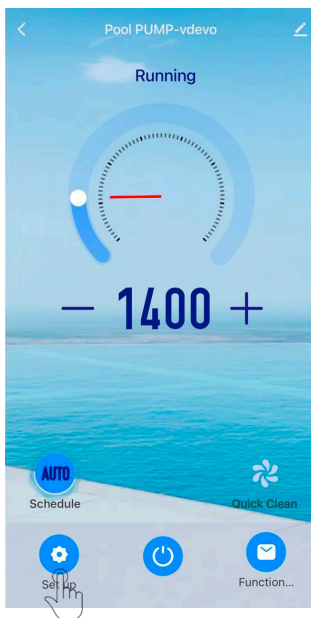

- Click Mode duration to set the running time of Pump at this stage, and click “confirm”.

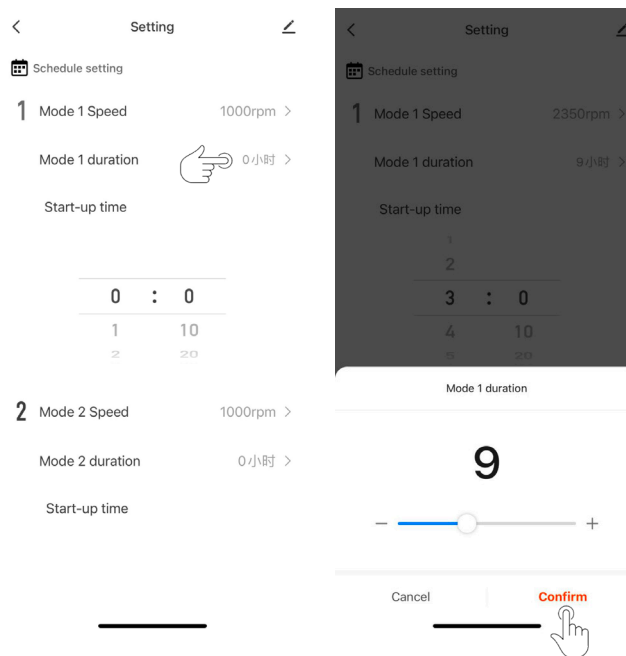

- Click “Start-up time” to adjust the start time of the Pump run, click “confirm” to confirm.

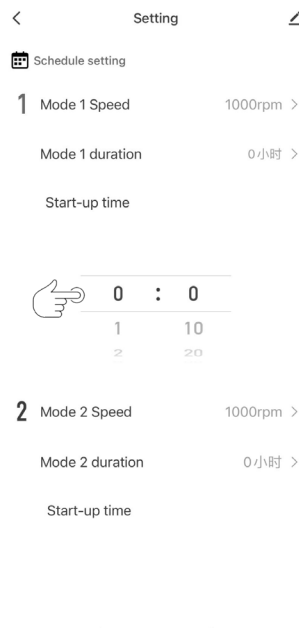

- Return to the original page click “AUTO” to start Pump and run the set Schedule.

### 3) Quickclean pattern

- Click “Set up” to enter the setting interface, slide the page to “Quick clean setting” and adjust the PUMP running speed (the default speed is 2850rpm).

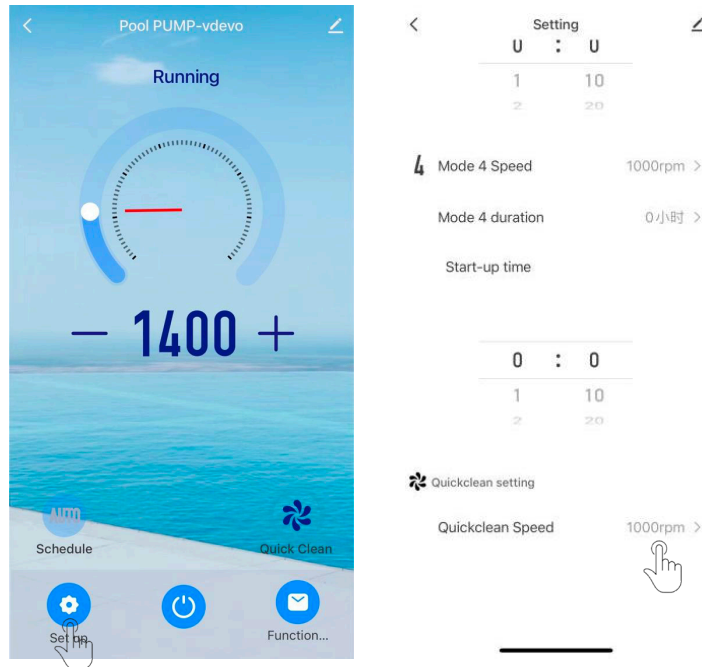

- Click on the “Quick clean” to start the PUMP.

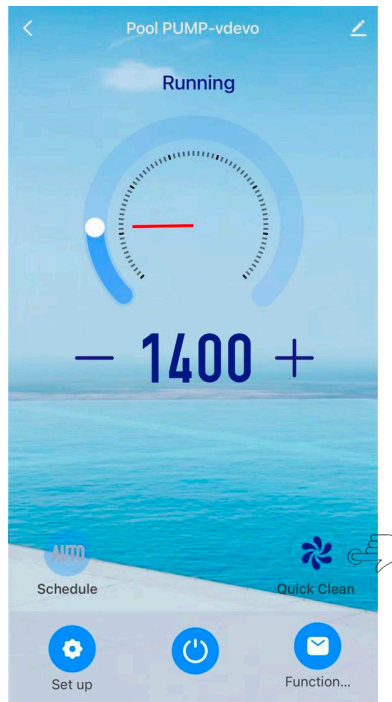

#### 4) Manual speed adjustment

- The current pump speed can be adjusted by sliding the dial or pressing “+” and “-” .

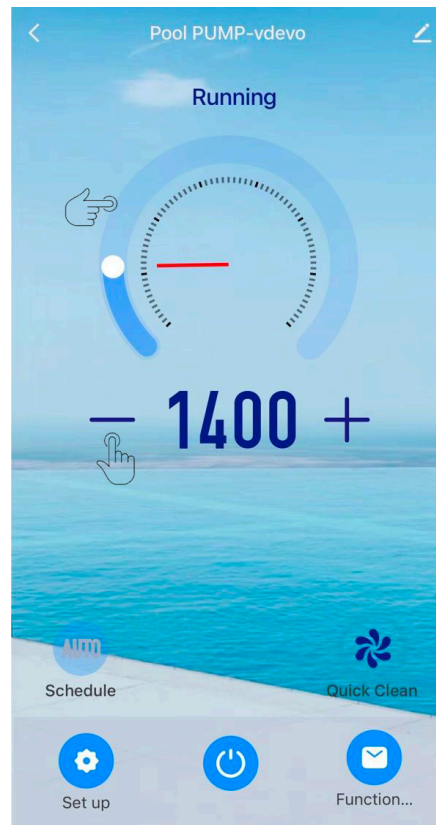

#### For Your Attention:

1. Do not manually adjust the rotation speed within 5min ;
2. Manual speed adjustment is only valid for the current stage. If you want to fix it at this speed point for a long time, please adjust it in the “Schedule” mode.



## IG2-2022VS

<b>Input voltage nominal</b>	230 VAC
<b>Input current</b>	8 Amps
<b>Input frequency</b>	1PH, L1-L2 or L-N, 50 or 60 Hz
<b>Max input watts</b>	1700 W
<b>Max shaft horsepower</b>	2.2 HP
<b>Speed range</b>	1000 - 3450 RPM

<b>Environmental enclosure rating</b>	NEMA Type 3 / IPX5
---------------------------------------	--------------------

### Ambient condition range

<b>Storage</b>	-40°C to +60°C (-40°F to +140°F)
<b>Operating</b>	0°C-50°C (32°-122°F)
<b>Humidity</b>	Relative 0-95% Non-condensing

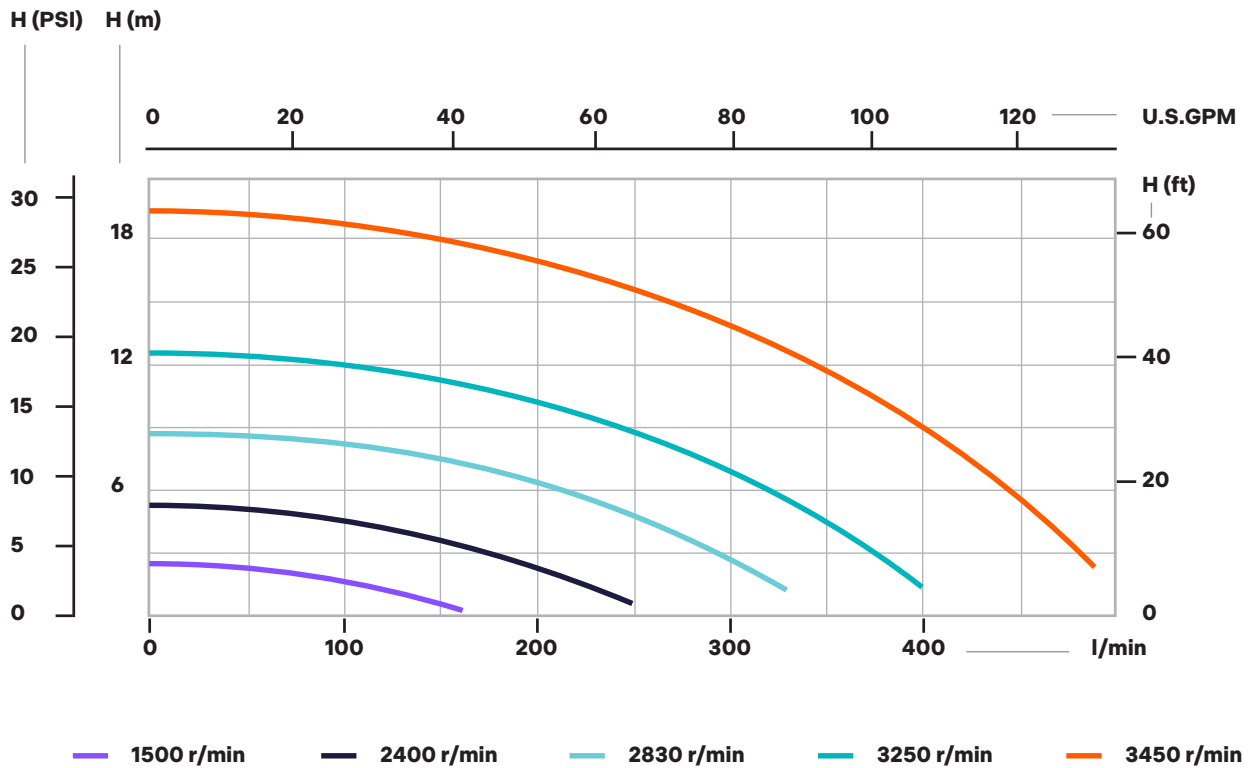

# Pump structure & parts

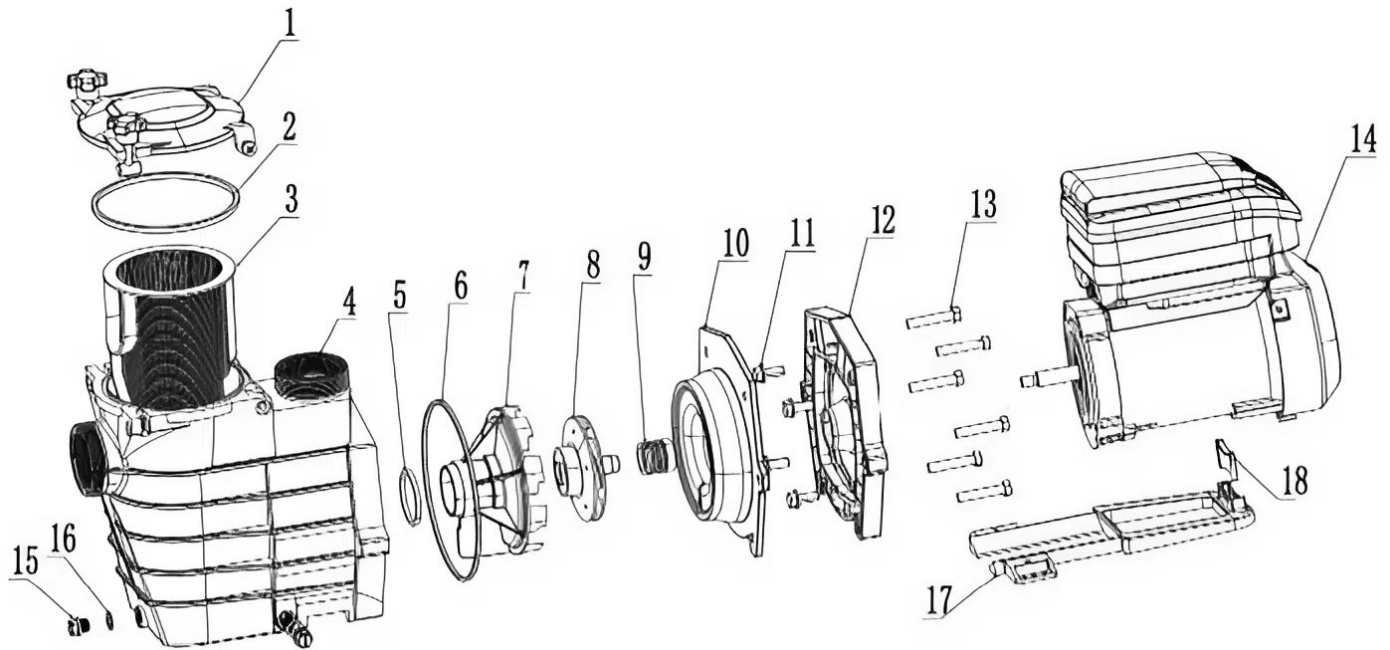

Ref. No.	Part No.	Description	Quantity
1	47258502000	Transparent cover	1
2	5431239080	Gasket $\phi 149.4 \times \phi 159.8 \times 8.2$	1
3	47258508001	Basket	1
4	47258501080	Strainer Housing	1
5	5432040080	O-Ring $\phi 60.2 \times \phi 52.4 \times 4.85$	1
6	5431240080	Gasket $\phi 188.4 \times \phi 195.1 \times 4$	1
7	47258001080	Diffuser	1
8	647278172000	Impeller	1
9	5028348000	Seal Assembly	1
10	47258504080	Pump cover	1
11	5225003000	Screw 3/8-16*11/2 UNC	4
12	47258505080	Transition pump cover	1
13	5225008000	Screw 3/8-16UNC*50.8mm	6
14	5023581000	Motor	1
15	48860105080	Drain Plug	2
16	5432002080	Gasket $\phi 19 \times \phi 13 \times 1.57$	2
17	47258506080	Mounting foot	1
18	47254205080	Supporting foot	1

Use only GoPool genuine replacement parts.

# Pump dimensions

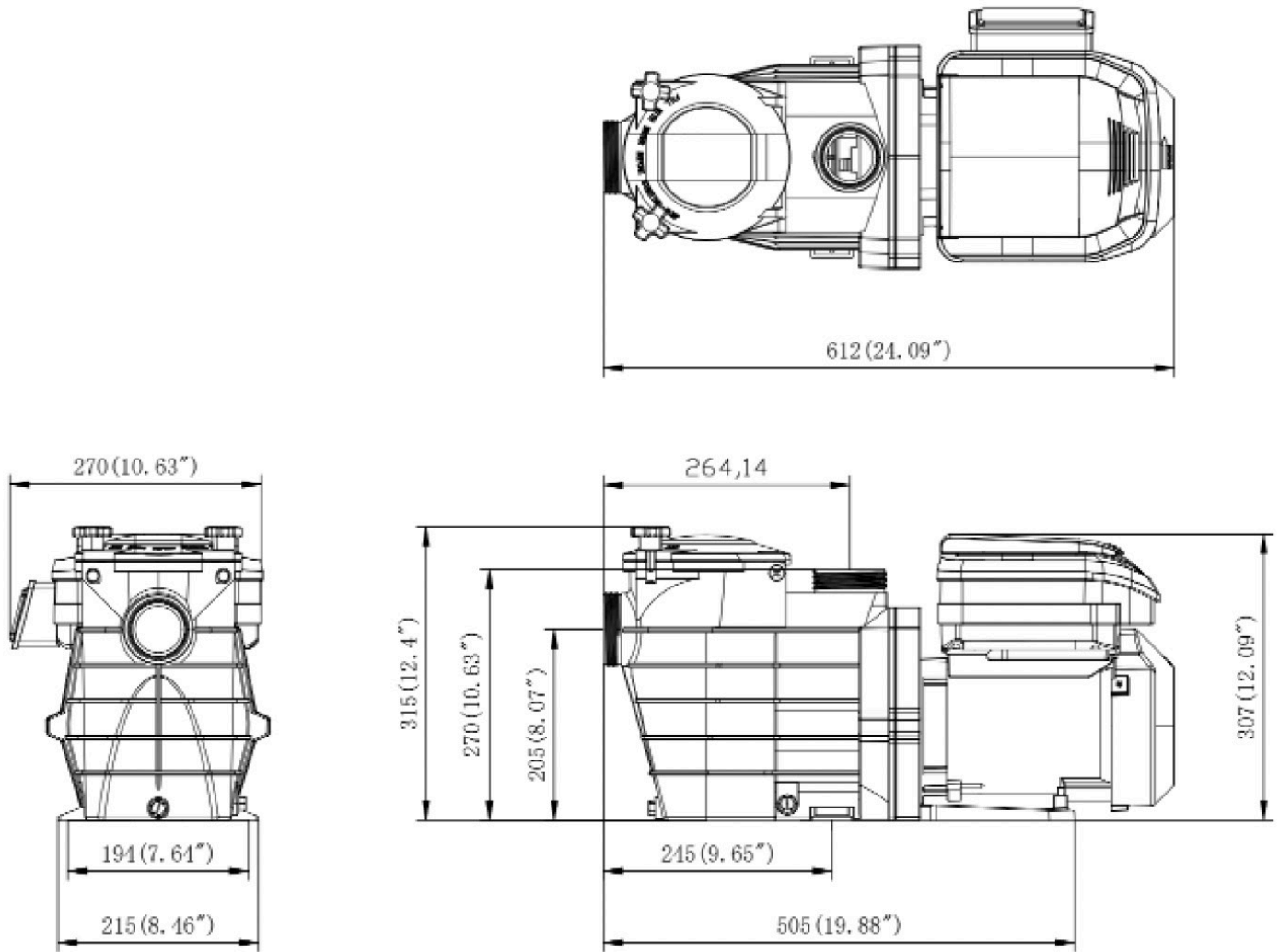

# GoPool

Need parts or accessories ?  
[GoPool.com](http://GoPool.com)