

GoPool IL60

IL-Series Owner's Manual



Scan to register your
product warranty

GoPool

Warranty registration

Thank you for choosing GoPool! Register your product today to activate your warranty and get quick, hassle-free support when you need it.



Scan to register your product warranty



WARNING

This equipment must be installed and serviced according to the information found in this manual. Improper installation can create hazards which could result in property damage, serious injury or death. Improper installation will void the warranty.

Table of contents

Installation.....	1
Operation	3

Installation



⚠ Please read the following carefully and keep this user manual save for future reference.

Ref.	Power	Lumens	Voltage	LED	
				Type	Quantity
IL60-GP-10RGBW-P	10W	500lm	AC 12V	SMD5054	36

DIMENSION

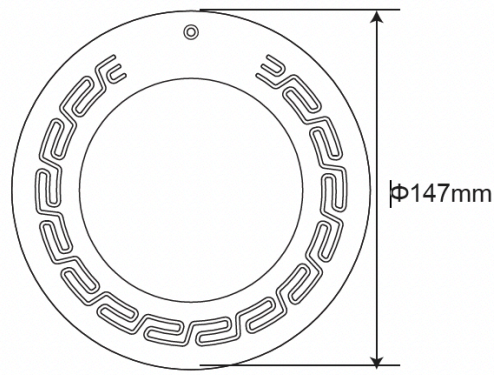

INSTALLATION

01. Input voltage is AC12V. The lamps must be connected with transformer.
02. The junction box is located at least 1200mm from the edge of the pool.

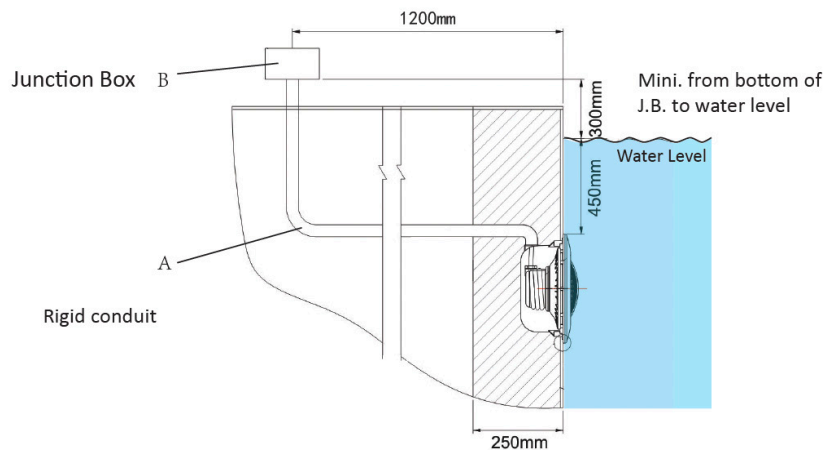

Figure 1

03. The mounting bracket must be properly installed so that the top edge of the light's lens is at least 450mm below the water level in the pool. **See Figure 1.**

04. Put the LED panel in the ABS/SS frame , fix the panel , PC clips with 4pcs screws.



05. Hang the W4012 on the original niche (Pentair/Hayward/Jandy ...), lock it with a screw.



06. If the cable connection is done underwater, the connection part must be waterproof protected (use waterproof cable gland or fill with epoxy glue). Otherwise, the water will come in the lamp through the wires.



07. Connect all wires to the corresponding circuit wires in the junction box and feed epoxy.

08. Before operating the light for more than 10 seconds fill pool until the light is completely submerged in water.



Selecting colors

To select a color show mode (1-7) or static color (8-12), turn the wall switch OFF/ON a specific number of times. Each number (1-12) shown above corresponds to the number of times to power-cycle the switch to activate a color light show or static color.

Hold: Lock the current mode. (switch OFF/ON 13 times)

Return: Return to the previous locked mode. (switch OFF/ON 14 times)

Memorizing the color

When power is switched off (more than 5 seconds) to the RGB color lights, the last color show mode or fixed color will be saved.

CAUTION:

01. Input voltage is AC12V. The lamps must be connected with transformer.
02. Before operating the light for more than 10 seconds fill pool until the light is completely submerged in water.

GoPool 12 Color Programs (For RGB or RGBW ON/OFF)

1	Butterfly Wings	Cycles through white, purple, blue and green colors
2	Galaxy Eye	The colors flashe quickly, full of energy
3	Rainbow Sky	Gradual change blue-purple-red-yellow-cyan-green-purple
4	Summer Dream	Blue and green appear alternately
5	France Romatic	Transition between red, white and blue
6	Desert Passion	Dramatic transitions of orange, red and purple
7	Mexico Night	Richer and deeper color changes between red-purple-yellow-green
8	Ocean Heart	Static Blue
9	Spring Green	Static Green
10	Cherry Kiss	Static Red
11	Noble White	Static White
12	Lavender Love	Static Purple
13	Hold Mode	Lock the current mode
14	Return Mode	Return to the previous locked mode

(Suitable for MC-15 control box)

GoPool

Need parts or accessories ?
GoPool.com